

**GENERAL PURPOSE ACCUTRAK ROTARY MODELS CONTAINING:
Mechanical Switches, Inductive Proximity Sensors or
Magnum Proximity Switches**

IOM: Tech-504Q

Revision: -

Prepared By: C. Spence

Date: 11/4/15

Drafting Work Order: 21632

ECN: N/A

Reviewed By: T. Lee

Date: 11/4/15

Approved By: Rhonda Frey

Date: 11/4/15

This IOM contains confidential information and is issued in confidence on the condition that it be returned on demand and not be copied, reproduced, disclosed to others or used in manufacture of the subject matter thereof without the written consent of Westlock Controls

1.**Warnings**

- Never remove enclosure cover or make/break electrical connections with power connected to the unit.
Perform all wiring in accordance with site, local and National Electric Code of practice. This IOM is not used for hazardous area units.
- Confirm that the AccuTrak model being installed has been rated appropriately for the area (see unit ID label).
- Confirm that supply power to switches is within rated specifications listed on the unit identification label.
- Only install the AccuTrak monitor into environments that are suitable to the materials of construction.

**2.****Installation****2.1. Mounting Instructions**

Required Tools: Open-end spanner or adjustable spanner to fit all sizes of hex head bolts in the mounting kit.

1. Obtain a mounting kit suited for the actuator/AccuTrak.
2. Attach the mounting bracket and coupler (if required) to the AccuTrak with the screws and washers provided. Tighten hand tight only.
3. Attach the AccuTrak and bracket to the actuator. Tighten hand tight only.
4. Ensure proper axial alignment between AccuTrak shaft, coupler and actuator shaft. Failure to ensure this alignment could result in long-term stress-related failure of unit shaft in high cycle or high torque applications.
5. Once alignment has been achieved, tighten ALL screws with the appropriate spanner adjustable spanner.

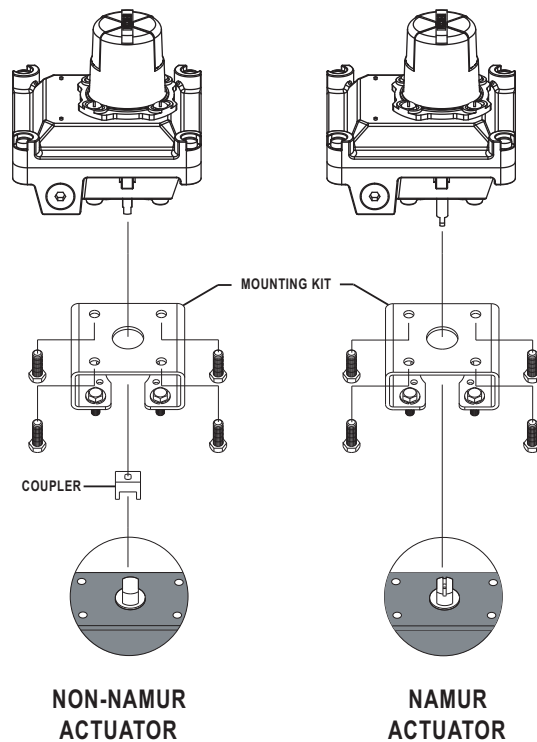

2.2. Calibration

Note 1: Switch actuation can be confirmed using a signal detection device such as a multimeter or ohmmeter, set for “continuity”.

Note 2: For NAMUR inductive proximity sensors, use appropriate test meter, or equivalent to check sensor actuation and calibration. If the proper meter is not available, contact the factory for additional assistance with the test procedure.

Note 3: Adjust cams by hand by pushing/pulling the cam against the shaft spring to disengage from the mating spline, rotating to adjust and re-engaging firmly onto spline.

Required Tools: Signal detection device (see note 1); slotted screw drivers or Allen Key for cover screws

Switch Adjustment (two switches):

1. Remove unit cover as follows: loosen (but do not remove) captive screws, rotate cover slightly to grip corners, pull firmly.
DO NOT PRY COVER WITH TOOLS.
2. With valve in the closed position, adjust bottom cam until bottom switch (#2) actuates.
3. Stroke valve to the open position, adjust top cam until top switch (#1) actuates.
4. Cycle actuator several times to confirm proper switch indication at each end of stroke. Finely adjust cams if necessary.
5. Skip to Field Wiring section or replace unit cover, applying approximately 20 in-lbs of torque to cover screws.

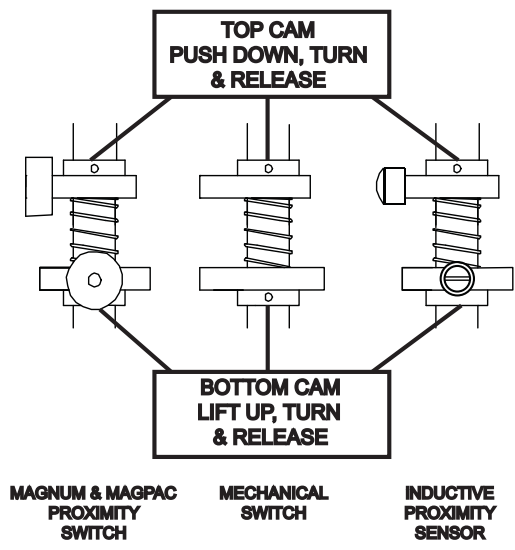

Switch Adjustment (four switches, no CS transmitter option):
 Follow steps as above for the calibration of two switches but adjust the first and third cams from the top for switches #1 and #2 and the second and fourth cams from the top for switches #3 and #4 (see illustration below).

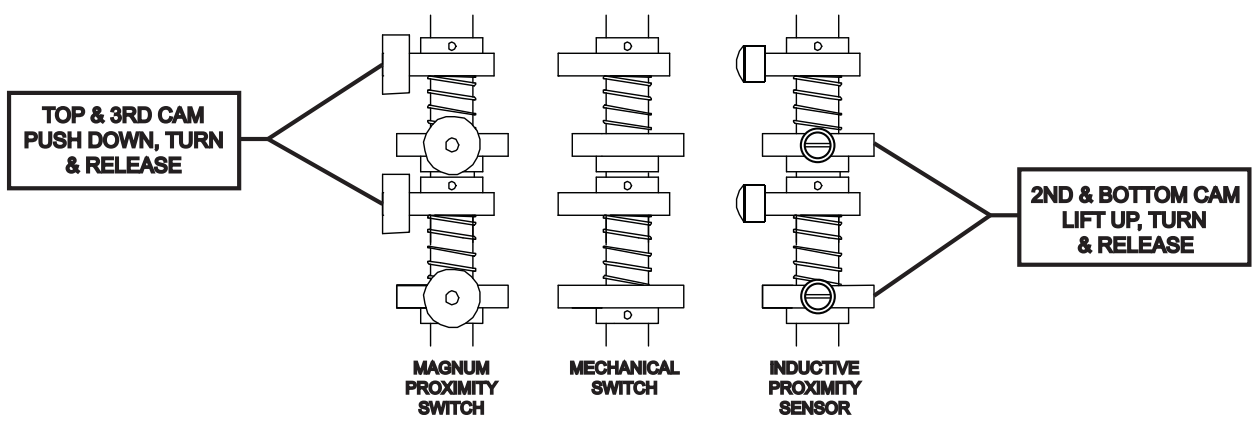

Transmitter setting (optional CS transmitter):
 For the calibration of optional current signal (CS) transmitter, see Westlock Controls Installation/Operations Manual TECH-301UK.

Beacon Adjustment:

Note: Skip this step if cover is flat or Beacon already displays the correct valve status.

Required Tools: slotted screw driver for #12 screws.

1. For two-way OPEN/CLOSED: remove, rotate and re-fasten outer beacon to ensure correct displayed flow path with valve/actuator flow path is shown.
2. For three-way flow paths: remove, rotate and re-fasten outer beacon and/or inner beacon coupler to ensure correct displayed flow path with valve/actuator flow path is shown.

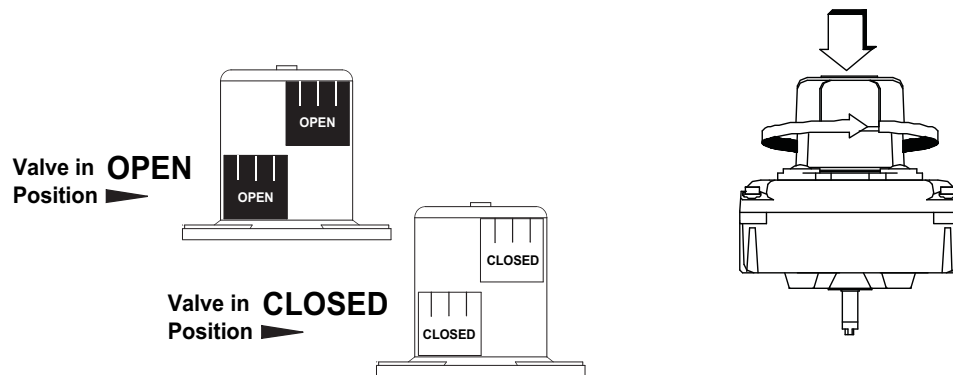

3. Field Wiring

See the warnings section of this document for important warnings pertaining to the wiring of this unit. Remove and replace cover before and after wiring, per instructions given in the Switch Adjustment section above.



1. Wire the AccuTrak monitor strictly according to the wiring diagram on the inside of the enclosure cover.
2. Confirm that the ground wire is secure under the green or marked grounding screw in the enclosure.
3. Seal all unused conduit entries as required with suitably certified plugs having an ingress protection rating of IP67 or better, if plugs are not supplied.
4. Ensure that only suitably certified cable glands are used, having an ingress protection rating of IP67 or better.
5. Ensure that the temperature rating of all field wiring meets the service temperature range of the application.