

## 2600 SERIES ATEX IECEX AND UK CA CERTIFIED

### INSTALLATION AND OPERATING INSTRUCTIONS

Installation and operating instructions for Westlock 2600 series valve position (AccuTrak) and control (Quantum) monitors with mechanical switches, inductive proximity sensors or Magnum proximity switches

AccuTrak 2600 position monitor

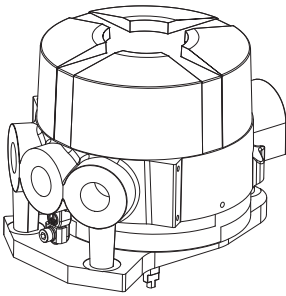

Quantum 2600 control monitor

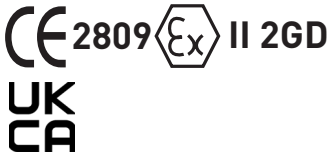
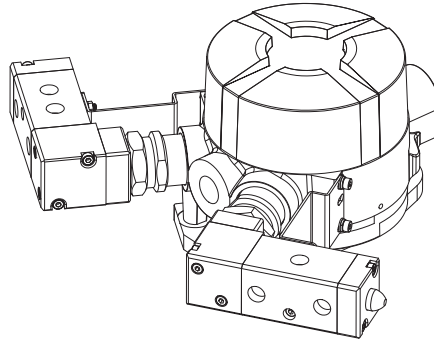

ITS21UKEX0360X  
 IECEx ETL 17.0009X  
 ETL21ATEX0056X  
 Ex db IIC T\* Gb Tamb -\*°C to +\*°C  
 Ex tb IIIC T\*°C Db Tamb -\*°C to +\*°C IP6X  
 Ambient variation: -60°C to +85°C (T4/T130°C); -60°C to +80°C (T5/T95°C);  
 -60°C to +65°C (T6/T80°C)  
 For position monitors (without a coil) the T4 ambient range may be -60°C to +110°C  
 Environmental parameters: 80 kPa (0.8 bar) to 110 kPa (1.1 bar).  
 Air with normal oxygen content, typically 21%.

#### 1 PRODUCT DESCRIPTION

The 2600 series valve position / control monitor provides two methods of end of travel indication by the means of mechanical switches, inductive proximity sensors or proximity switches and an external visual indicator.

For applications that require position feed back, ancillary components such as a 4-20 mA current signal transmitter or a resistive signal feed back can be installed.

The 2600 series enclosure is available in two materials; cast aluminum or 316 stainless steel. The enclosure construction comprises of a housing with a screwed cover.

The housing has the option of up to three cable entries for connection to an external power source via appropriate ATEX and IECEx certified cable glands:

M20 x 1.5p, M25 x 1.5p, ½" - 14 NPT or ¾" - 14 NPT.

**Note:** Before installation of this product, please ensure that the product and its certification is suitable for the intended application. This product uses various O-ring material and an Eastar copolyester visual indicator as standard.

If the equipment is likely to come into contact with aggressive substances, then it is the responsibility of the user to take suitable precautions that prevent it from being adversely affected, thus ensuring that the type of protection provided by the equipment is not compromised.

Installation of any cable entry devices, conduit entry devices or blanking devices shall not compromise the degree of ingress protection level IP6X for use in the presence of combustible dusts.

The unit has an ingress protection of IP66/67 and therefore any conduit device fitted must maintain this.



#### Warning

*Do not open when energized or when an explosive atmosphere is present.*



#### Warning

*Electrostatic hazard, clean only with damp cloth.*



#### NOTE

These products have been certified with a cable entry temperature rise of 4°C. Ensure that this is taken into consideration when selecting suitable cabling for the ambient temperature in which the product is to be used.



#### NOTE

These products are not intended to be assembled directly to process pipe work etc. that is heated or cooled to temperatures outside of the range as indicated above.

# 2600 SERIES ATEX IECEx AND UK CA CERTIFIED

## INSTALLATION AND OPERATING INSTRUCTIONS

### 2 MOUNTING INSTRUCTIONS

**2.1** Attach a mounting bracket to the housing base with the M8 fasteners provided with the mounting bracket. Install shaft adaptor / coupler, as appropriate to either the actuator pinion or unit shaft.

**2.2** To ensure that the 2600 series unit is mounted correctly, it may be necessary to stroke the actuator to the fully closed position.

**Warning**  
 Before stroking the actuator at any point during this mounting procedure, please ensure that the process is safe to do so and keep hands away from moving parts.

**2.3** With the actuator in the correct position, attach the 2600 series unit / bracket to the actuator using the hardware provided in the mounting kit.

**2.4** Unscrew the cover and keep in a safe place. Ensure that the Jack screw (socket head cap screw) remains in the housing (See Figure 1).

**2.5** To set the switches, lift the bottom cam and turn until the switch has activated and then release. The spring will push the cam back onto the splined shaft (Figure 2).

**2.6** Stroke the actuator to the opposite end of travel. Set the top cam by pushing down and turning the cam until the switch is activated (Figure 2).

**2.7** Stroke the actuator from one end of stroke to the other several times to check the switch operation. If the switches require adjustment, repeat steps 2.5 to 2.7.

**2.8** Beacon setting - if fitted  
 Loosen the beacon fixing screw, see Figure 1, rotate beacon window (outer beacon) to indicate appropriate open or closed text as corresponding to actuator position.

**2.9** Tighten beacon fixing screw sufficiently to prevent movement of window.

FIGURE 1  
Standard enclosure

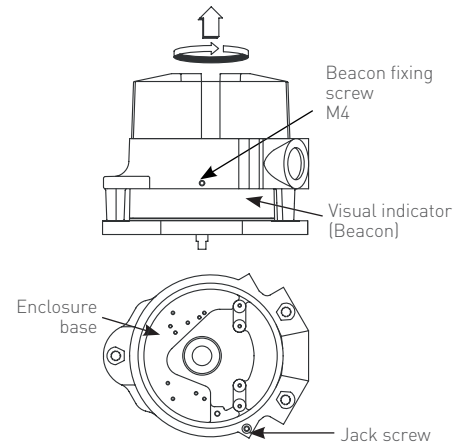
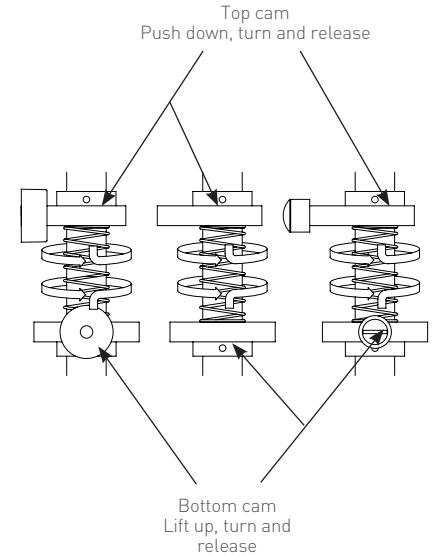

FIGURE 2



# 2600 SERIES ATEX IECEX AND UK CA CERTIFIED

## INSTALLATION AND OPERATING INSTRUCTIONS

### 3 FIELD WIRING AND INSTALLATION



#### Warning

The 2600 series should always be handled with care when the cover is removed and wired to electrical power source. Ensure cover lock is engaged when replacing cover



#### NOTE

Before electrical installation, please read and follow the wiring diagram located inside the cover. The electrical ratings can be found on the product identification label.

- 3.1 Field wiring must be carried out in accordance with site, local and national electrical codes / requirements. This includes special attention to earth bond to the enclosure using the internal and external earth points provided.
- 3.2 Installation of this product shall be carried out by competent personnel in accordance with the applicable code of practice such as EN 60079-14 or IEC 60079-14.

- 3.3 The 2600 series housing can offer up to three of the following conduit entries as standard; M20 x 1.5p, M25 x 1.5p, 1/2" - 14 NPT or 3/4" - 14 NPT (four conduit entries are available as an option). These entries are detailed on the product identification label found on the product housing. Please see Figure 3 for conduit positions.
- 3.4 The certification applies to equipment without cable glands. When mounting the flameproof enclosure in the hazardous area, only suitably rated IP66/67 ATEX and IECEX certified flameproof glands must be used.
- 3.5 All unused cable entries must be plugged with a suitably rated IP66/67 ATEX and IECEX certified blanking devices.

FIGURE 3

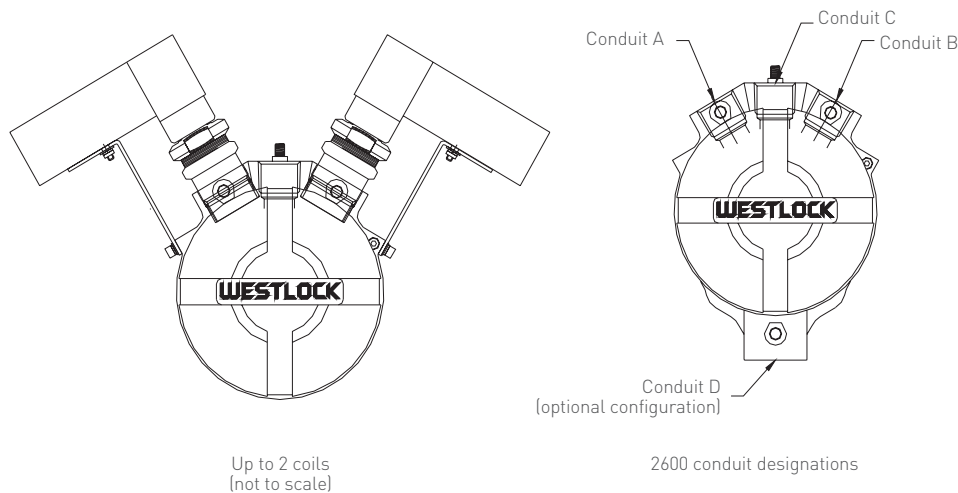

## 2600 SERIES ATEX IECE<sub>x</sub> AND UK CA CERTIFIED INSTALLATION AND OPERATING INSTRUCTIONS

---

**3.6** Thread adaptors shall satisfy the requirements of the specific type of protection.

**3.7** The first two digits of the Westlock nomenclature signifies the series with the third digit defining whether the product has a visual beacon or not.

The table below details the applicable ambient ranges:

| Series code | Cover type | T class    | Ambient temperature range aluminium or stainless steel |
|-------------|------------|------------|--|
| 264*        | Beacon     | T6 (80°C)  | -60°C to +65°C   |
| 264*        | Beacon     | T5 (95°C)  | -60°C to +80°C   |
| 264*        | Beacon     | T4 (130°C) | -60°C to +85°C ☒                                       |
| 266*        | No Beacon  | T6 (80°C)  | -60°C to +65°C   |
| 266*        | No Beacon  | T5 (95°C)  | -60°C to +80°C   |
| 266*        | No Beacon  | T4 (130°C) | -60°C to +85°C ☒                                       |

### NOTE

☒ For AccuTrak position monitors without a coil, the T4 range is -60°C to +110°C.

**3.8** The fourth digit designates the switch / sensor type. The following table details the most common switch / sensor types together with their electrical ratings.

| Series code/switch designation   | Electrical rating  |
|----------------------------------|--|
| 26*5 Mechanical (SPDT)           | 15 A - 125 or 250 V AC; 6 A - 24 V DC                    |
| 26*6 Mechanical (DPDT)           | 10 A - 125 or 250 V AC; 10 A - 28 V DC; 0.2 A - 125 V DC |
| 26*7 Inductive proximity sensors |  |
| 26*9 Magnum ratings              | 3 A - 120 V AC; 1.5 A - 240 V AC or 2 A - 24 V DC        |

**Note:** The series code signifies the maximum electrical rating of the product, suitable overloading protection must be provided to prevent these values being exceeded.

**3.9** The tenth digit designates the coil voltage and type. The following table details the voltage and power ratings:

| Voltage / type | Power rating |
|----------------|--------------|
| 12 V DC        | 0.7 W        |
| 24 V DC        | 0.7 W        |
| 125 V DC       | 1 W          |
| 90-120 V AC    | 4 VA         |
| 220-240 V AC   | 4 VA         |

# 2600 SERIES ATEX IECEx AND UK CA CERTIFIED

## INSTALLATION AND OPERATING INSTRUCTIONS

**3.10** The 2600 series valve control monitor has the option for position feedback by the means of a resistive signal (RS) or current signal (CS) transmitter.

The RS transmitter electrical ratings are - 1 K Ohms (standard) or 5 K or 10 K Ohms (optional).  
The CS transmitter electrical ratings are - current loop 4-20 mA at 18 to 24 V DC.  
See separate installation & operating instructions VCIOM-04112

**3.11** Before replacing the enclosure cover, ensure that both of the housing and cover threads are clean and undamaged. Screw the cover onto the housing ensuring that it is not cross threaded and turns freely. Continue tightening the cover until metal to metal condition is achieved between the bottom edge of the cover and the housing surface.

Lock the cover as follows:  
Using a 3 mm A/F Allen key / wrench, rotate the Jack screw in an anti-clockwise direction until sufficient pressure has been applied to the bottom edge of the cover to prevent the cover from being removed by hand.

### 4 PRODUCT REPAIR AND SERVICE

- 4.1** Inspection of this product shall be carried out by suitably trained personnel in accordance with the applicable code of practice such as EN 60079-17 or IEC 60079-17.
- 4.2** In the event of any repairs that may be required such tasks must be carried out by suitably trained/competent personnel in accordance with the applicable code of practice such as EN 60079-19 or IEC 60079-19.
- 4.3** The certification of this product has been approved based on the material of construction as per the drawings listed in the schedule within this certificate. Any replacement parts that are not made in accordance to the listed drawing will invalidate the approval / certification.
- 4.4** Replacement parts must be purchased through Westlock Controls or via an approved Westlock Controls distributor.

### 5 OPERATING AND MAINTENANCE INSTRUCTIONS FOR FALCON SOLENOID VALVES. (QUANTUM CONTROL MONITORS ONLY)

#### 5.1 General description

5.1.1 The Falcon II solenoid valve incorporates elastomer static seals through which a shaped spool moves and are manufactured for 3 or 5 way operation. 3 way is normally used for pilot control of the other relay valves or for the operation of single acting cylinders. 5 way is normally used to control the action of double acting cylinders. The seal spacer assembly forms individual annular chambers opposite each valve port and the grooved spool either closes or allows flow between adjacent chambers, hence the position of the spool determines which ports are open or closed.

The spool is moved by way of a manually or mechanically operated mechanism normally against a return spring. Operation may be by application or removal of a pilot air supply acting as a pilot piston. This form of control is utilized for electrical actuation where integral solenoid valves control the pilot air supply.

#### 5.1.2 Optional features - Falcon II

- 5.1.2.1 No-voltage release (latching)**  
With the coil first energized, the palm button is then manually moved and latched.  
The inward movement of the palm button causes the valve to shift.  
When the coil is de-energized, the palm button and latching mechanism are automatically tripped, allowing the valve to return to its original position. See Figure 4A.
- 5.1.2.2 Manual locking override**  
Manually depress palm button and rotate clockwise for maintained condition, must manually disengage to return to original position. See Figure 4B.
- 5.1.2.3 Momentary override**  
Spring return momentary push type, must hold in to actuate. See Figure 4C.
- 5.1.2.4 Hex drive maintained override**  
Insert Allen key in hex head screw and rotate clockwise (4-5 turns) to shift spool. Valve will stay put until hex head screw is rotated counter clockwise (4-5 turns) back to original position. See Figure 4D.

FIGURE 4

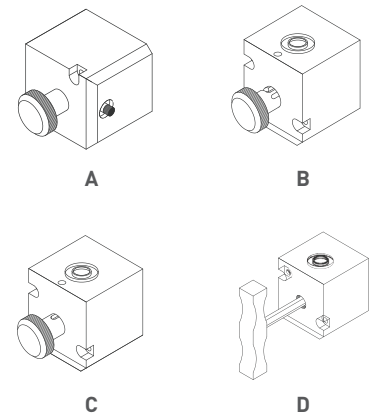

# 2600 SERIES ATEX IECEx AND UK CA CERTIFIED

## INSTALLATION AND OPERATING INSTRUCTIONS

### 5.1.2.5. D/C - Dual coil option

5 way valves are available with a coil/pilot valve on each end of the Falcon II valve, coil 'A' and coil 'B'.

When coil 'A' is energized the valve will shift. If coil 'A' is then de-energized, the valve will remain in this position.

The valve will not return to the original state until coil 'A' is de-energized and coil 'B' is energized.

The process is the same for coil 'B'.

**Note:** For dual coil valves.

The valve may be in either position upon installation. Refer to the air flow diagrams and energize the appropriate coil (with air) to reset valve to the desired position.

Dual coil valves require both an electrical signal and air pressure to operate.

See air flow diagram for air pressure requirements.

If either or both inputs are lost the valve will remain in it's current position.

Both coils should never be energized simultaneously.

### 5.1.3 Specifications

Operating pressure: 45 - 140 psig / 3.0 - 10 bar

Operating media: Non lubricated filtered air to 20 microns

### 5.1.4 Field wiring

Complete the electrical wiring in accordance with national and local electrical requirements.

The ground wire should be secure under the earth screw. Check all screws for tightness.

### 5.1.5 (Air line) Installation considerations

Air mains and lines should be large enough to avoid excessive pressure loss under conditions of maximum flow. Air lines should be installed with as few restrictions as possible if the cost of compressed air is to be kept to a minimum. Sharp turns in piping should be avoided for more efficient air flow and economical air power. It is advisable to pitch the mains in the direction of air flow so that both gravity and air flow will carry the water to traps or water legs located at frequent intervals.

To help in preventing condensed moisture from reaching the point of usage, down pipes should never be taken directly from the bottom of air pipes or mains.

Connection should be made at the top of the main and a long radius return bend used.

### 5.1.6 Air flow

Pipe sizes are normally determined on semi empirical lines, basis for selection being an acceptable pressure drop e.g. not more than 10% of the applied pressure. In sizing pipes, consideration should be given to likely future demands, as a system will be inefficient if the demand outgrows the supply. It is always better to over size mains as this will reduce air velocity and make water separation more effective.

FIGURE 5

Air line designation, 1/4" NPT or BSP air ports for inlet, outlet and exhaust on 1.1 Cv valves. The 3.5 Cv valve (optional) has 1/2" NPT or BSP ports.

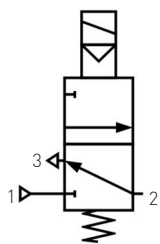

#### Spring return valve

Description of operation:

Solenoid de-energized - air flows from Outlet Port 2 to Exhaust Port 3.

Solenoid energized - air flows from Inlet Port 1 to Outlet Port 2.

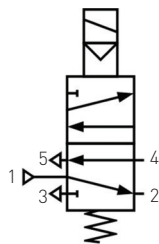

#### Spring return valve

Description of operation:

Solenoid de-energized - air flows from Inlet Port 1 to Outlet Port 2 and exhausts from Port 4 to Port 5.

Solenoid energized - air flows from Inlet Port 1 to Outlet Port 4 and exhausts from Port 2 to Port 3.

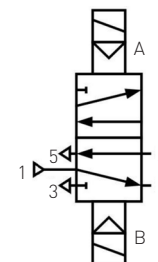

#### Dual coil valve

Description of operation:

Coil B de-energized - air flows from Inlet Port 1 to Outlet Port 2 and exhausts from Port 4 to Port 5.

Coil A energized - air flows from Inlet Port 1 to Outlet Port 4 and exhausts from Port 2 to Port 3.

# 2600 SERIES ATEX IECEX AND UK CA CERTIFIED

## INSTALLATION AND OPERATING INSTRUCTIONS

### 5.1.7 Air service equipment

The importance of proper filtration (20 micron) and lubrication of the air supply to pneumatic equipment can never be over-emphasized as a means of decreasing friction and preventing corrosion and wear due to moisture and abrasive solids being present in the air supply.

At higher pressures than recommended, pneumatic equipment can wear excessively with no significant increase in output and compressed air is consequently wasted.

There is much to be gained, therefore, from providing pneumatic equipment with serviced air by including suitable air line filters, pressure regulators and lubricants in the installation.

### 5.1.8 Tubes and fittings

The use of copper, stainless steel, nylon or polyethylene tube is recommended for piping up air circuits and equipment. As a general rule, pipe threaded fittings should not be assembled to a specific torque because the torque required for a reliable joint varies with thread quality, port and fitting materials, sealant used, and other factors.

The suggested method of assembling pipe threaded connections is to assemble them finger tight and then wrench tighten further to a specified number of turns from finger tight.

The assembly procedure given below is for reference only, the fitting should not be over tightened for this will lead to distortion and most likely, complete valve failure.

1. Inspect port and connectors to ensure that the threads on both are free of dirt, burrs and excessive nicks.
2. Apply sealant/lubricant or PTFE tape to the male pipe threads. With any sealant tape, the first one or two threads should be left uncovered to avoid system contamination.
3. Screw the connector into the port to the finger tight position.
4. Wrench tighten the connector approximately 1-2 turns (to seal) from finger tight. Again this is only reference - the fitting should NOT be over tightened.

### Maintenance

Routine maintenance is usually confined to the periodic replenishment of Dow Corning 111 lubricant or equivalent to spool and spring.

FIGURE 6  
Exploded assembly of 3 and 5 way 1.1 Cv Falcon II

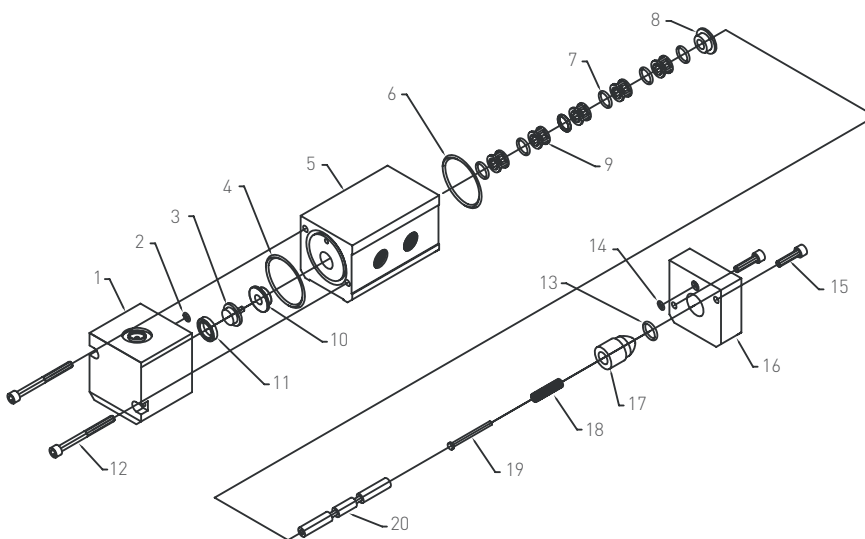

### PARTS LIST

| No. | Part name            |
|-----|----------------------|
| 1.  | Pilot piston end cap |
| 2.  | O-ring               |
| 3.  | Pilot piston         |
| 4.  | O-ring               |
| 5.  | Valve body           |
| 6.  | O-ring               |
| 7.  | O-ring               |
| 8.  | Bush                 |
| 9.  | Spacer               |
| 10. | Bush                 |
| 11. | Pilot piston seal    |
| 12. | Cap screws           |
| 13. | O-ring               |
| 14. | O-ring               |
| 15. | Cap screws           |
| 16. | Spring end cap       |
| 17. | Tell-tale cover      |
| 18. | Spring               |
| 19. | Tell-tale pin        |
| 20. | Spool                |

# 2600 SERIES ATEX IECEx AND UK CA CERTIFIED

## INSTALLATION AND OPERATING INSTRUCTIONS

FIGURE 7  
Exploded assembly of 5 way 3.5 C<sub>v</sub> Falcon

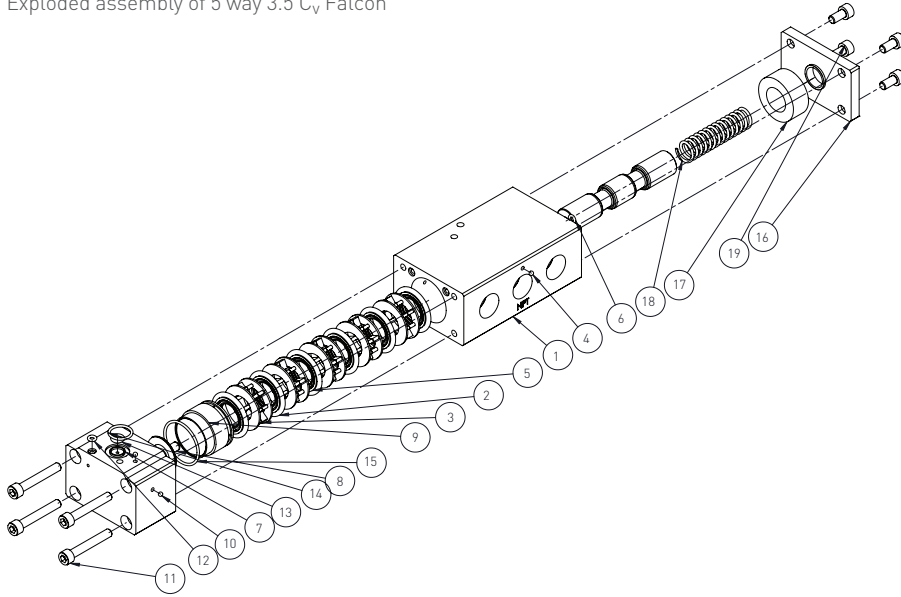

### PARTS LIST

| No. | Part name           |
|-----|---------------------|
| 1   | Valve body          |
| 2   | O-ring              |
| 3   | Spacer              |
| 4   | Ball                |
| 5   | Bonded seal         |
| 6   | O-ring              |
| 7   | Pilot end cap       |
| 8   | Pilot piston        |
| 9   | Pilot piston sleeve |
| 10  | Ball                |
| 11  | Cap screws          |
| 12  | O-ring              |
| 13  | O-ring              |
| 14  | O-ring              |
| 15  | O-ring              |
| 16  | Spring end cap      |
| 17  | Bush                |
| 18  | Spring              |
| 19  | Cap screws          |

### Engineering document reference

These installation and operating instructions are based on the latest engineering update, reference ECN#13045, and form part of the certification for the 2600 series. To ensure you have the most recent version of this IOM, please check the document library on our website ([westlockcontrols.com](http://westlockcontrols.com)) to ensure this document has the latest ECN number.

### Translations

Where translated the copy is taken from the original English document VCIOM-05081-EN as checked by the relevant notified certification body and therefore the original English document will prevail. No rights or liability can be derived from any translation.

### Previous documents

VCIOM-05081 replaces all previous installation and operating instructions for the 2600 series including VCIOM-02677/02678/04123/04124 and TECHUK-16/16Q/43/43Q.



### WARNING

*This symbol warns the user of possible danger. Failure to observe this warning may lead to personal injury or death and/or severe damage to equipment.*



### ATTENTION

*This symbol identifies information about operating the equipment in a particular manner that may damage it or result in a system failure. Failure to observe this warning can lead to total failure of the equipment or any other connected equipment.*



### NOTE

*This symbol draws attention to information that is essential for understanding the operation and/or features of the equipment.*