



KEYSTONE FIGURE 320 WAFER AND FIGURE 322 LUGGED BUTTERFLY VALVES

The Figure 320 is an economical resilient seated butterfly valve with dimensions according ISO standards



FEATURES

- Bubble-tight shut-off at full rating in both directions.
- One piece, specially profiled, wafer thin disc stem.
- Extended body neck allows free access to actuator where pipe insulation has been fitted.
- The seat and disc are the only two parts in contact with the medium.
- Face to face dimensions according ISO 3202 Part 3, K1 (ISO 5752 series 20) and DIN EN 558-1, series 20.
- The F320 wafer version has four flange locating holes for end of line service under certain conditions.
- Standard actuation:
 - Handle (F414) on DN 50-200 valves.
 - Gear operators (F455) on DN 250-300.
- The F322 lugged version is suitable for bi-directional end of line service.
- Suitable for pneumatic, electric and hydraulic actuation.

GENERAL APPLICATION

Figure 320/322 is designed for applications requiring shut-off control. The valve has a non-replaceable seat and can be used in combination with manual or a gear operator, or any other common type of pneumatic, electric or hydraulic actuator.

TECHNICAL DATA

Size range: Figure 320 (wafer style)
DN 50-300
Figure 322 (lugged style)
DN 50-300

Pressure: 16 bar (in line and end of line)

Temperature (°C): Minus 29°C to 120°C (EPDM seat)
Minus 15°C to 100°C (NBR seat)

End connections

F320

Between flanges

DN 50-300: PN 6-10-16
ASME 150

End of line

DN 50-300: PN 16
ASME 150

DN 50-150: PN 10

F322

DN 50-300: PN 6-10-16
ASME 150

DN 50-300: PN 6-10-16
ASME 150



KEYSTONE FIGURE 320 WAFER AND FIGURE 322 LUGGED BUTTERFLY VALVES

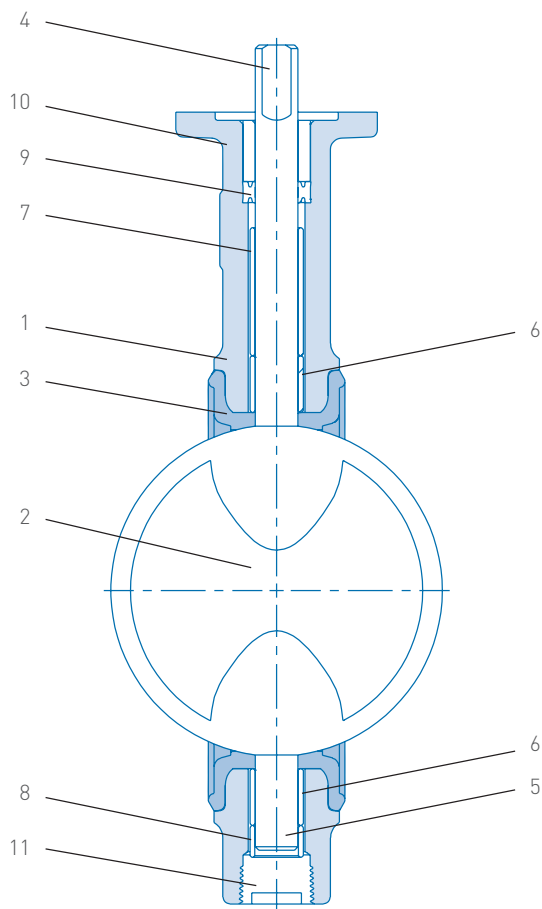

PART LIST

No.	Description	Material	Standard	Material number
1	Body	Ductile iron	ASTM 536 Gr 65-45-12	DIN 0.7040
2	Disc	Stainless steel	ASTM A 351 Gr CF8M	DIN 1.4408
		Aluminum bronze	ASTM B 148 UNS C95200 A	DIN 2.0940.01
		Nickel aluminum bronze	BS EN 1982 CC 333 G	DIN 2.0975.01
3	Seat	EPDM	-	-
		NBR	-	-
4	Top stem	416 S/S	ASTM A 582, 416 cond. H	-
5	Bottom stem	416 S/S	ASTM A 582, 416 cond. H	-
6	Bushing	Sintered bronze	ASTM B438	-
7	Upper spacer	-	-	-
8	Lower spacer	-	-	-
9	Packing	-	-	-
10	Upper bushing	Thermoplastic polyester	ASTM D 4507 TPES 110M10	A22310
11	Plug	-	-	-

KEYSTONE FIGURE 320 WAFER AND FIGURE 322 LUGGED BUTTERFLY VALVES

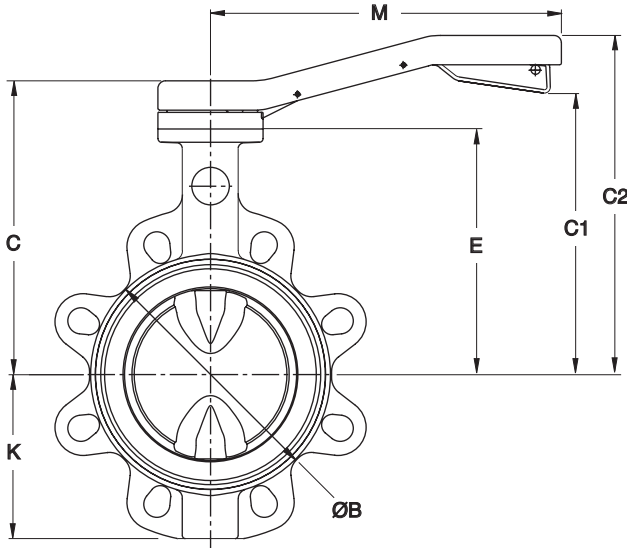
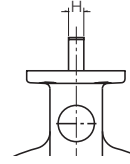
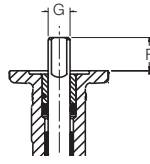
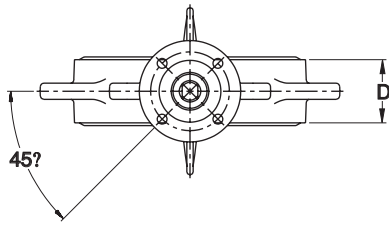

Figure 320 wafer

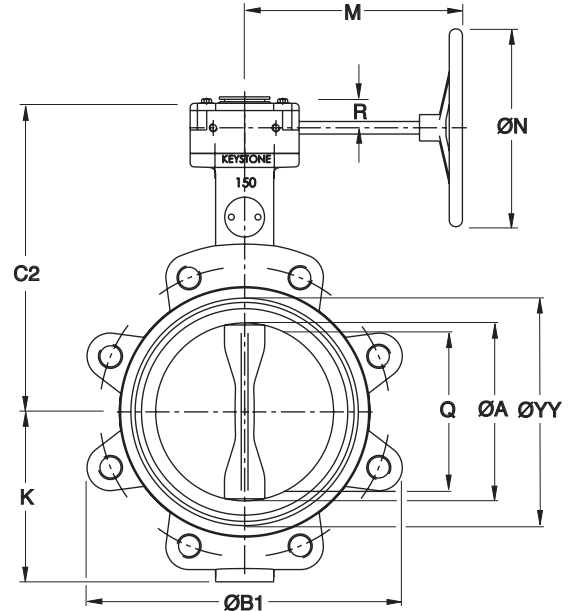

Figure 322 lugged

DIMENSIONS (mm)

Size	ØA	ØB	ØB1	C	C1	C2	D	E	Stem connections			ISO Type	K	M	ØN	Q	R	ØYY	Mass kg*		K _v fully open
									F	ØG _{H9}	H _{0.05}								F320	F322	
50	52	98	157	172	147	197	43	135	25	12.00	8	F05	78	230	31	87	3.7	4.4	108		
65	64	116	177	194	180	230	46	150	30	15.88	11	F07	83	300	47	98	5.9	6.5	217		
80	77	126	192	204	190	240	46	160	30	15.88	11	F07	91	300	63	114	6.4	7.6	409		
100	103	156	225	224	110	260	52	180	30	15.88	11	F07	105	300	90	146	7.9	9.7	807		
125	128	182	254	239	225	275	56	195	30	20.00	14	F07	127	300	116	168	9.4	12.7	1251		
150	147	207	279	254	240	290	56	210	30	20.00	14	F07	140	300	137	197	11.3	14.1	1946		
200	198	264	336	240	311	60	240	30	30	20.00	14	F07	174	327	300	190	37	258	26.1	30.2	3516
250	249	317	406	275	346	68	275	50	50	30.00	22	F12	203	327	300	241	37	309	35.0	43.0	5806
300	300	373	476	310	381	78	310	50	50	30.00	22	F12	235	327	300	291	37	354	46.1	55.4	8910

NOTES

Dimensions are nominal ± 1 mm.

1. Q is the disc chordal dimension at face of valve for disc clearance into pipe fitting or equipment.
2. Valves DN 50-200 are supplied standard with handles (F414).
Valves DN 250-300 are supplied standard with gear operators (F455).
3. YY is outside diameter of seat face.

* The mass shown includes the standard operator.

ISO 5211 MOUNTING DETAILS

Type	PCD	Bolt holes
F05	50	4 x Ø7
F07	70	4 x Ø9
F12	125	4 x Ø14

KEYSTONE FIGURE 320 WAFER AND FIGURE 322 LUGGED BUTTERFLY VALVES

SIZING TORQUES (Nm)

ΔP in kPa	Size DN								
	50	65	80	100	125	150	200	250	300
I*									
350	13	19	26	37	58	81	148	241	345
700	13	20	27	40	63	88	164	271	387
1000	14	21	30	44	70	99	188	315	451
1400	15	23	33	49	80	113	219	374	536
1600	15	24	35	51	85	120	235	403	578
II*									
350	14	21	29	42	66	93	169	274	392
700	14	22	31	45	71	100	185	303	434
1000	15	23	33	49	78	111	208	347	498
1400	16	26	36	54	88	125	240	406	583
1600	17	27	38	56	93	132	255	435	625
III*									
350	15	23	32	48	74	105	190	306	439
700	16	24	34	50	79	112	206	336	481
1000	16	26	36	54	86	122	229	380	545
1400	17	28	40	59	96	136	261	439	629
1600	18	29	41	61	101	143	276	468	672

* Application I, II, III

NOTES

- Application I:** Water, seawater, lubricating types of hydrocarbons. Temp.: 0-80°C; valve opens at least once a month.
Application II: All other liquid applications and lubricating gasses.
Application III: Non lubricating and dry media.
- The charted maximum sizing operating torque is the sum of all friction and resistance for opening and closing of the disc against the indicated pressure differential.
- The effect of dynamic torque is not considered in tabulation.
- In sizing operators it is not necessary to include safety-factors.
- Rated K_v = the volume of water in m³/hr that will pass through a given valve opening at a pressure drop of 1 bar.

TRIM CODES

Figure no.	Trim Code	Body	Disc	Shaft	Seat
F320/322	112	Ductile iron	S/S	S/S	EPDM
F320/322	116	Ductile iron	S/S	S/S	NBR
F320/322	135	Ductile iron	NiAlBz	S/S	EPDM
F320/322	137	Ductile iron	NiAlBz	S/S	NBR
F320/322	333	Ductile iron	AlBz	S/S	EPDM
F320/322	334	Ductile iron	AlBz	S/S	NBR

MAXIMUM ALLOWABLE SHAFT TORQUES (Nm)

Size DN	Torques
50	75
65	184
80	184
100	184
125	374
150	374
200	374
250	1353
300	1353