

Diaphragm Valve, Metal

Construction

The GEMÜ 653 / 654 manually operated 2/2-way metal diaphragm valve has a stainless steel bonnet and is available in two versions - GEMÜ 653 has a handwheel in high temperature and chemically resistant plastic, GEMÜ 654 a stainless steel handwheel. The handwheel is non-rising (except diaphragm size 8) and has a standard optical position indicator. The valve is available with two bonnet versions: Design D has concealed bolt mounting in the bonnet and is only suitable for 2/2-way bodies. Design T is suitable for T valve, Multi-port valve, Tank bottom valve and 2/2-way valve bodies.

Features

- Suitable for inert, corrosive*, liquid and gaseous media
- CIP/SIP cleaning and sterilizing capabilities
- Autoclave capability
- Insensitive to particulate media
- Surface finishes down to 0.25 µm, electropolished
- Designed according to GMP (Good Manufacturing Practice)
- Versions according to ATEX on request

Advantages

- The handwheel design allows minimal heat sink thus reducing the danger of burns injuries
- The service life of the diaphragm is increased to a maximum by the patented optional seal adjuster (US-patent 6,691,737 B2)
- Optional flow direction, will seal in either flow direction up to full operating pressure
- Optional mounting position
- Option
 - Lockable handwheel
 - Mounting for proximity switches for position feedback

*see information on working medium on page 2

Sectional drawing

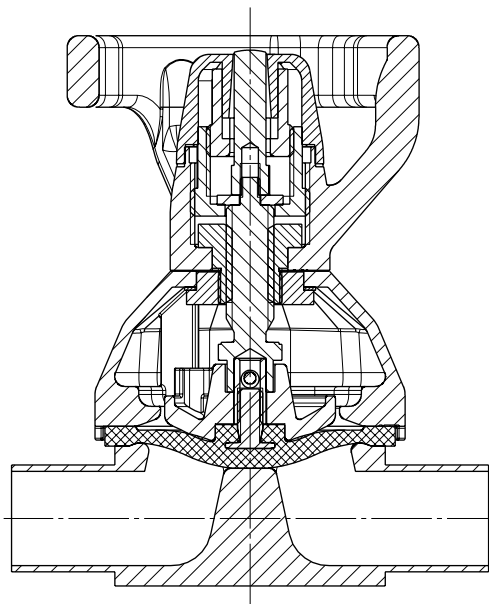

GEMÜ 653

Bonnet version "T"



Bonnet version "D"



GEMÜ 654

Bonnet version "T"



Bonnet version "D"

Technical data

Working medium

Corrosive, inert, gaseous and liquid media which have no negative impact on the physical and chemical properties of the body and diaphragm material.

Operating temperature max. 150 °C
(dependent on medium wetted materials)

The valve will seal in both flow directions up to full operating pressure (All pressures are gauge pressures).

Bonnet material

Bonnet	A4 stainless steel
Cap (DN 10 - DN 40)	PEEK
Cap (DN 50 - DN 100)	PES
653 handwheel	PPS glass filled
654 handwheel	A4 stainless steel

Ambient conditions

Max. ambient temperature Standard 60 °C

Max. ambient temperature Accessory MAG 35 °C

Temperature at mounting point for proximity switches see ambient temperature diagram below

Values measured at 25°C ambient temperature

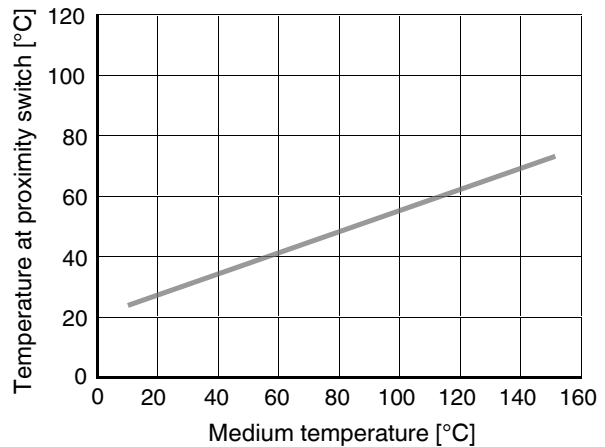

Diaphragm size	Operating pressure [bar]	
	EPDM/FPM	PTFE
8	0 - 10	0 - 6
10	0 - 10	0 - 6
25	0 - 10	0 - 6
40	0 - 10	0 - 6
50	0 - 10	0 - 6
80	0 - 10	0 - 6
100	0 - 10	0 - 6

All pressures are gauge pressures. Operating pressure values were determined with static operating pressure applied on one side of a closed valve. Sealing at the valve seat and atmospheric sealing is ensured for the given values. Information on operating pressures applied on both sides and for high purity media on request.

Version with PTFE diaphragm up to 10 bar possible with bonnet special function „H“ and forged valve body.

Kv values [m³/h]

MG	DN	DIN Code 0	DIN 11850 Series 1 Code 16	DIN 11850 Series 2 Code 17	DIN 11850 Series 3 Code 18	SMS 3008 Code 37	ASME BPE Code 59	EN ISO 1127 Code 60
8	4	0.5	-	-	-	-	-	-
	6	1.1	-	-	-	-	-	1.2
	8	1.3	-	-	-	-	0.6	2.2
	10	-	2.1	2.1	2.1	-	1.3	-
	15	-	-	-	-	-	2.0	-
10	10	-	2.4	2.4	2.4	-	2.2	3.3
	15	3.3	3.8	3.8	3.8	-	2.2	4.0
	20	-	-	-	-	-	3.8	-
25	15	4.1	4.7	4.7	4.7	-	-	7.4
	20	6.3	7.0	7.0	7.0	-	4.4	13.2
	25	13.9	15.0	15.0	15.0	12.6	12.2	16.2
40	32	25.3	27.0	27.0	27.0	26.2	-	30.0
	40	29.3	30.9	30.9	30.9	30.2	29.5	32.8
50	50	46.5	48.4	48.4	48.4	51.7	50.6	55.2
	65	-	-	77.0	-	68.5	68.5	96.0
80	80	-	-	111.0	-	80.0	87.0	111.0
	100	-	-	194.0	-	173.0	188.0	214.0

Kv values determined acc. to IEC 534 standard, inlet pressure 6 bar, Δp 1 bar, stainless steel valve body and soft elastomer diaphragm.
MG = diaphragm size

Technical data

Diaphragm temperature range [°C]

Diaphragm	Liquid Media		Steam (Sterilisation)	Code
	Min.	Max.		
EPDM	-10	90	150 °C, max. 60 min	13/3A
EPDM	-10	90	150 °C, max. 60 min	16/6A
EPDM	-10	90	150 °C, max. 180 min	17
PTFE	-10	90	Constant temperature* 150 °C	52/5A
PTFE	-10	90	Constant temperature* 150 °C	5E
FPM	-10	90	not applicable	4/4A
PTFE	-10	90	150 °C, max. 40 min	5F

* The valves concerned must be serviced regularly if steam is applied continuously

Order data

Body configuration	Code
Tank valve body	B**
2/2-way body	D
Multi-port design	M**
T body	T*
* For dimensions see T Valves brochure	
** Dimensions and versions on request	

Connection	Code
Butt weld spigots	
Spigots DIN	0
Spigots DIN 11850, series 1	16
Spigots DIN 11850, series 2	17
Spigots DIN 11850, series 3	18
Spigots DIN 11866, series A	1A
Spigots DIN 11866, series B	1B
Spigots JIS-G 3447	35
Spigots JIS-G 3459	36
Spigots SMS 3008	37
Spigots BS 4825, part 1	55
Spigots ASME BPE	59
Spigots EN ISO 1127	60
Spigots ANSI/ASME B36.19M, Schedule 10s	63
Spigots ANSI/ASME B36.19M, Schedule 40s	65
Threaded connections	
Threaded sockets DIN ISO 228	1
Threaded spigots DIN 11851	6
One side threaded spigot, other side cone spigot and union nut, DIN 11851	62
Aseptic unions on request	

Connection	Code
Flanges	
Flanges EN 1092 / PN16 / form B, length EN 558, series 1, ISO 5752, basic series 1	8
Flanges ANSI CLASS 125/150 RF, length MSS SP-88	38
Flanges ANSI CLASS 125/150 RF, length EN 558, series 1, ISO 5752, basic series 1	39
Clamp connections	
Clamps ASME BPE for pipe ASME BPE, length ASME BPE	80
Clamps DIN 32676 series B for pipe EN ISO 1127, length EN 558, series 7	82
Clamps ASME BPE for pipe ASME BPE, length EN 558, series 7	88
Clamps DIN 32676 series A for pipe DIN 11850, length EN 558, series 7	8A
Clamps SMS 3017 for pipe SMS 3008, length EN 558, series 7	8E
Aseptic clamps on request	
For overview of available valve bodies for GEMÜ 653/654 see page 13	

Valve body material	Code
1.4435 - BN2 (CF3M), investment casting Fe<0.5%	32
1.4435 (ASTM A 351 CF3M \cong 316L), investment casting	34
1.4408, investment casting	37
1.4408, PFA lined	39
1.4435 (316L), forged body	40
1.4435 (BN2), forged body Fe<0.5%	42

For further order data see page 4

Order data

Diaphragm material	Code
FPM	4 4A*
EPDM	13 3A*
EPDM	16 6A*
EPDM	17 17*
PTFE/EPDM convex, PTFE loose	5E**
PTFE/FPM convex, PTFE loose	5F
PTFE/EPDM, PTFE laminated	52 5A*
* for diaphragm size 8	
**For use with valve bodies see page 13	
Material complies with FDA requirements, except code 4 and 4A	

Control function	Code
Manually operated	0

Bonnet size	Code
Diaphragm size 8	0
Diaphragm size 10	1
Diaphragm size 25	2
Diaphragm size 40	3
Diaphragm size 50	4
Diaphragm size 80	5
Diaphragm size 100	6

Bonnet version	Code
For body configuration D (diaphragm size 10 - 50)	D
For body configurations B, D, M and T (diaphragm size 8 - 100)	T
Bonnet for special function for body configurations B, D, M and T (diaphragm size 10 - 100)	X

Bonnet function		Code
With seal adjuster and stroke limiter	(GEMÜ 653 diaphragm size 10 - 50) (GEMÜ 654 diaphragm size 8 - 100)	H
Without seal adjuster and without stroke limiter	(GEMÜ 653 diaphragm size 10 - 100) (GEMÜ 654 diaphragm size 8 - 100)	N
With seal adjuster	(diaphragm size 80 - 100)	S
Special versions		
With seal adjuster, stroke limiter and mounting for proximity switches M 8x1	(diaphragm size 10 - 50)	A*
With seal adjuster and mounting for proximity switches M 12x1	(diaphragm size 80 - 100)	
With seal adjuster, stroke limiter, locking device (both directions) and mounting for proximity switches M 8x1	(diaphragm size 10 - 50)	B*
With seal adjuster, locking device (both directions) and mounting for proximity switches M 12x1	(diaphragm size 80 - 100)	
With seal adjuster, stroke limiter and safety gland packing	(diaphragm size 10 - 50)	E*
With seal adjuster and safety gland packing	(diaphragm size 80 - 100)	
With seal adjuster, stroke limiter, locking device to prevent closing and mounting for proximity switches M 8x1	(diaphragm size 10 - 50)	F*
With seal adjuster, locking device to prevent closing and mounting for proximity switches M 12x1	(diaphragm size 80 - 100)	
With seal adjuster, stroke limiter, locking device to prevent opening and mounting for proximity switches M 8x1	(diaphragm size 10 - 50)	K*
With seal adjuster, locking device to prevent opening and mounting for proximity switches M 12x1	(diaphragm size 80 - 100)	
* only in connection with bonnet version X		

For further order data see page 4

Order data

Valve body surface finish, internal contour

		Forged body Code 40, 42	Investment casting Code 32, 34	Code
Ra ≤ 6.3 µm	blasted internal/external	-	X	1500
--	electropolished	-	X	1509
Ra ≤ 0.8 µm	mechanically polished internal, blasted external	X	X	1502
Ra ≤ 0.8 µm	electropolished internal/external	X	-	1503
Ra ≤ 0.6 µm	mechanically polished internal, blasted external	X	X	1507
Ra ≤ 0.6 µm	electropolished internal/external	X	-	1508
Ra ≤ 0.4 µm	mechanically polished internal, blasted external	X	-	1536
Ra ≤ 0.4 µm	electropolished internal/external	X	-	1537
Ra ≤ 0.25 µm	mechanically polished internal, blasted external	X	-	1527
Ra ≤ 0.25 µm	electropolished internal/external	X	-	1516

Ra acc. to DIN 4768; at defined reference points
Surface finish data refer to medium wetted surfaces

Order example	653	50	D	60	40	13	0	4	D	H		1503
Type	653											
Nominal size		50										
Body configuration (code)			D									
Connection (code)				60								
Valve body material (code)					40							
Diaphragm material (code)						13						
Control function (code)							0					
Bonnet size (code)								4				
Bonnet version (code)									D			
Bonnet function (code)										H		
Nominal size (mm)*												
Connection (code)*												
Surface finish (code)												1503

* only in T-valve version

Dimensions [mm]

Bonnet dimensions

MG	øB	A			A4			Weight [kg]
		H	N	S	H	N	S	
8	36	85	65	-	4.5	-	0.35	
10	63	86	-	-	2.0	-	0.65	
25	92	108	-	-	5.0	-	1.40	
40	114	145	-	-	9.0	-	2.20	
50	132	171	-	-	21.0	-	3.20	
80	211	231*	202	231	33.0*	18.0	7.80	
100	211	255*	223	255	43.0*	28.0	8.50	

*only GEMÜ 654

MG = diaphragm size

A4: projection of indicator spindle over highest point when bonnet is in the fully open position (approximate values)

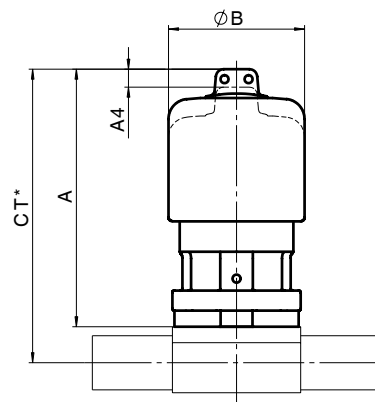
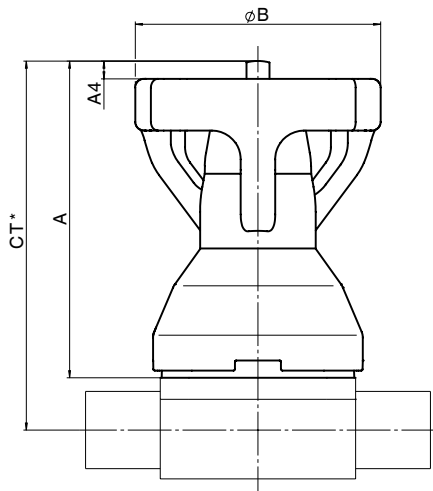

* CT = A + H1 (see body dimensions)

Dimensions: Special versions - Additional functions A, B, E, F, K,

MG	DN	øB	A	X MAG	X LOC	A4	Weight [kg]
10	10	63	124	107	73	2	0,7
25	15 - 25	92	159	112	78	5	1,7
40	32 - 40	114	192	119	85	9	2,8
50	50	132	233	125	91	21	4,3
80	65 - 80	211	290	142	108	33	10,5
100	100	211	323	152	118	43	12,5

X: only with additional functions B, F, K

MG = diaphragm size

A4: projection of indicator spindle over highest point when bonnet is in the fully open position (approximate values)

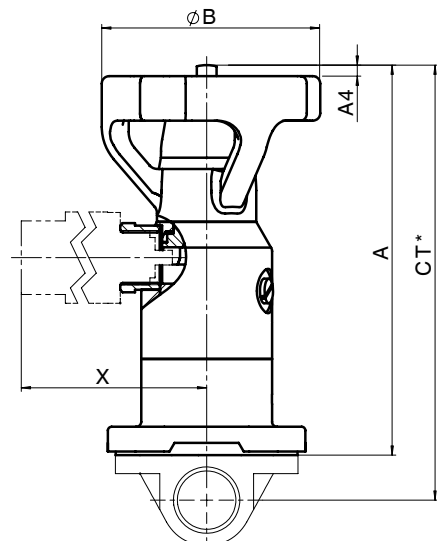

Body dimensions [mm]

Threaded sockets. connection code 1 Valve body material: investment casting (code 34. 37)

MG	DN	R	H	H1	t	L	SW2	Number of flats	Weight [kg]
8	8	G 1/4	19	8.5	12	72	17	2	0.09
10	12	G 3/8	23	10.5	13	55	22	2	0.17
	15	G 1/2	29	13.5	15	68	24	2	0.26
25	15	G 1/2	30	16.0	9	85	27	6	0.32
	20	G 3/4	33	17.0	10	85	32	6	0.34
	25	G 1	37	17.0	13	110	41	6	0.39
40	32	G 1 1/4	50	25.0	16	120	50	8	0.88
	40	G 1 1/2	52	25.0	18	140	55	8	0.93
50	50	G 2	69	34.0	18	165	70	8	1.56

MG = Diaphragm size

For materials see overview on page 13

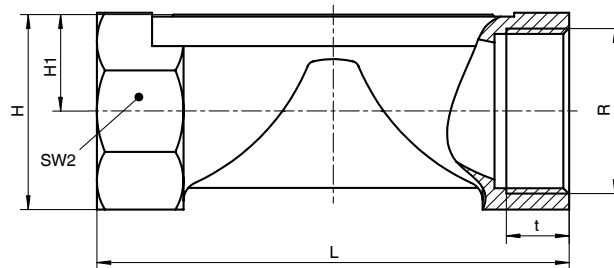

Body dimensions [mm]

Butt weld spigots, connection code 0, 16, 17, 18 Valve body material: Investment casting (code 34), forged body (code 40)

MG	DN	NPS	f*	øg*	L	c	H1*	H1**	DIN Series 0 Code 0		DIN 11850 Series 1 Code 16		DIN 11850 Series 2 Code 17		DIN 11850 Series 3 Code 18		Weight [kg]
									ød	s	ød	s	ød	s	ød	s	
8	4	-	-	-	72	20	8.5	6	1.0	-	-	-	-	-	-	0.09	
	6	-	-	-	72	20	8.5	8	1.0	-	-	-	-	-	-	0.09	
	8	1/4"	-	-	72	20	8.5	10	1.0	-	-	-	-	-	-	0.09	
	10	3/8"	-	-	72	20	8.5	-	-	12	1.0	13	1.5	14	2.0	0.09	
	15	1/2"	-	-	72	20	8.5	-	-	-	-	-	-	-	-	0.09	
10	10	3/8"	30	13.5	108	25	12.5	-	-	12	1.0	13	1.5	14	2.0	0.30	
	15	1/2"	30	13.5	108	25	12.5	18	1.5	18	1.0	19	1.5	20	2.0	0.30	
	20	3/4"	30	13.5	108	25	12.5	-	-	-	-	-	-	-	-	0.30	
25	15	1/2"	40	13.5	120	25	13.0	19.0	18	1.5	18	1.0	19	1.5	20	2.0	0.62
	20	3/4"	40	13.5	120	25	16.0	19.0	22	1.5	22	1.0	23	1.5	24	2.0	0.58
	25	1"	40	13.5	120	25	19.0	19.0	28	1.5	28	1.0	29	1.5	30	2.0	0.55
40	32	11/4"	68	13.5	153	25	24.0	26.0	34	1.5	34	1.0	35	1.5	36	2.0	1.45
	40	11/2"	75	13.5	153	25	26.0	26.0	40	1.5	40	1.0	41	1.5	42	2.0	1.32
50	50	2"	90	13.5	173	30	32.0	32.0	52	1.5	52	1.0	53	1.5	54	2.0	2.25
80	65	21/2"	-	-	216	30	-	62.0	-	-	-	-	70	2.0	-	-	8.60
	80	3"	-	-	254	30	-	62.0	-	-	-	-	85	2.0	-	-	8.00
100	100	4"	-	-	305	30	-	76.0	-	-	-	-	104	2.0	-	-	24.10

* only for investment cast design ** only for forged design MG = diaphragm size For materials see overview on page 13

Butt weld spigots, connection code 1A, 1B, 60 Valve body material: Investment casting (code 34), forged body (code 40)

MG	DN	NPS	f*	øg*	L	c	H1*	H1**	DIN 11866 Series A Code 1A		DIN 11866 Series B Code 1B		EN ISO 1127 Code 60		Weight [kg]
									ød	s	ød	s	ød	s	
8	4	-	-	-	72	20	8.5	-	-	-	-	-	-	0.09	
	6	-	-	-	72	20	8.5	8	1.0	10.2	1.6	10.2	1.6	0.09	
	8	1/4"	-	-	72	20	8.5	10	1.0	13.5	1.6	13.5	1.6	0.09	
	10	3/8"	-	-	72	20	8.5	13	1.5	-	-	-	-	0.09	
	15	1/2"	-	-	72	20	8.5	-	-	-	-	-	-	0.09	
10	10	3/8"	30	13.5	108	25	12.5	13	1.5	17.2	1.6	17.2	1.6	0.30	
	15	1/2"	30	13.5	108	25	12.5	19	1.5	21.3	1.6	21.3	1.6	0.30	
	20	3/4"	30	13.5	108	25	12.5	-	-	-	-	-	-	0.30	
25	15	1/2"	40	13.5	120	25	13.0	19.0	19	1.5	21.3	1.6	21.3	1.6	0.62
	20	3/4"	40	13.5	120	25	16.0	19.0	23	1.5	26.9	1.6	26.9	1.6	0.58
	25	1"	40	13.5	120	25	19.0	19.0	29	1.5	33.7	2.0	33.7	2.0	0.55
40	32	11/4"	68	13.5	153	25	24.0	26.0	35	1.5	42.4	2.0	42.4	2.0	1.45
	40	11/2"	75	13.5	153	25	26.0	26.0	41	1.5	48.3	2.0	48.3	2.0	1.32
50	50	2"	90	13.5	173	30	32.0	32.0	53	1.5	60.3	2.0	60.3	2.0	2.25
80	65	21/2"	-	-	216	30	-	62.0	70	2.0	76.1	2.0	76.1	2.0	8.60
	80	3"	-	-	254	30	-	62.0	85	2.0	88.9	2.3	88.9	2.3	8.00
100	100	4"	-	-	305	30	-	76.0	104	2.0	114.3	2.3	114.3	2.3	24.10

* only for investment cast design ** only for forged design MG = diaphragm size For materials see overview on page 13

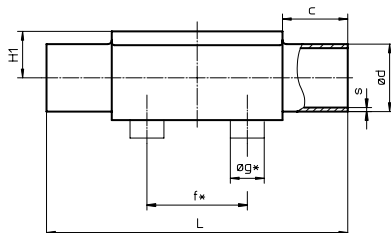

Body dimensions [mm]

Butt weld spigots, connection code 35, 36, 37 Valve body material: Investment casting (code 34), forged body (code 40)

MG	DN	NPS	f*	øg*	L	c	H1*	H1**	JIS-G 3447 Code 35		JIS-G 3459 Code 36		SMS 3008 Code 37		Weight [kg]
									ød	s	ød	s	ød	s	
8	4	-	-	-	72	20	8.5		-	-	-	-	-	-	0.09
	6	-	-	-	72	20	8.5		-	-	10.5	1.20	-	-	0.09
	8	1/4"	-	-	72	20	8.5		-	-	13.8	1.65	-	-	0.09
	10	3/8"	-	-	72	20	8.5		-	-	-	-	-	-	0.09
	15	1/2"	-	-	72	20	8.5		-	-	-	-	-	-	0.09
10	10	3/8"	30	13.5	108	25	12.5		-	-	17.3	1.65	-	-	0.30
	15	1/2"	30	13.5	108	25	12.5		-	-	21.7	2.10	-	-	0.30
	20	3/4"	30	13.5	108	25	12.5		-	-	-	-	-	-	0.30
25	15	1/2"	40	13.5	120	25	13.0	19.0	-	-	21.7	2.10	-	-	0.62
	20	3/4"	40	13.5	120	25	16.0	19.0	-	-	27.2	2.10	-	-	0.58
	25	1"	40	13.5	120	25	19.0	19.0	25.4	1.2	34.0	2.80	25.0	1.2	0.55
40	32	1 1/4"	68	13.5	153	25	24.0	26.0	31.8	1.2	42.7	2.80	33.7	1.2	1.45
	40	1 1/2"	75	13.5	153	25	26.0	26.0	38.1	1.2	48.6	2.80	38.0	1.2	1.32
50	50	2"	90	13.5	173	30	32.0	32.0	50.8	1.5	60.5	2.80	51.0	1.2	2.25
80	65	2 1/2"	-	-	216	30	-	62.0	63.5	2.0	76.3	3.00	63.5	1.6	8.60
	80	3"	-	-	254	30	-	62.0	76.3	2.0	89.1	3.00	76.1	1.6	8.00
100	100	4"	-	-	305	30	-	76.0	101.6	2.0	114.3	3.00	101.6	2.0	24.10

* only for investment cast design ** only for forged design MG = diaphragm size For materials see overview on page 13

Butt weld spigots, connection code 55, 59, 63, 65 Valve body material: Investment casting (code 34), forged body (code 40)

MG	DN	NPS	f*	øg*	L	c	H1*	H1**	BS 4825 Code 55		ASME BPE Code 59		ANSI/ASME B36.19M 10s Code 63		ANSI/ASME B36.19M 40s Code 65		Weight [kg]
									ød	s	ød	s	ød	s	ød	s	
8	4	-	-	-	72	20	8.5		-	-	-	-	-	-	-	-	0.09
	6	-	-	-	72	20	8.5		-	-	-	-	10.3	1.24	10.3	1.73	0.09
	8	1/4"	-	-	72	20	8.5		6.35	1.2	6.35	0.89	13.7	1.65	13.7	2.24	0.09
	10	3/8"	-	-	72	20	8.5		9.53	1.2	9.53	0.89	-	-	-	-	0.09
	15	1/2"	-	-	72	20	8.5		12.70	1.2	12.70	1.65	-	-	-	-	0.09
10	10	3/8"	30	13.5	108	25	12.5		9.53	1.2	9.53	0.89	17.1	1.65	17.1	2.31	0.30
	15	1/2"	30	13.5	108	25	12.5		12.70	1.2	12.70	1.65	21.3	2.11	21.3	2.77	0.30
	20	3/4"	30	13.5	108	25	12.5		19.05	1.2	19.05	1.65	-	-	-	-	0.30
25	15	1/2"	40	13.5	120	25	13.0	19.0	-	-	-	-	21.3	2.11	21.3	2.77	0.62
	20	3/4"	40	13.5	120	25	16.0	19.0	19.05	1.2	19.05	1.65	26.7	2.11	26.7	2.87	0.58
	25	1"	40	13.5	120	25	19.0	19.0	-	-	25.40	1.65	33.4	2.77	33.4	3.38	0.55
40	32	1 1/4"	68	13.5	153	25	24.0	26.0	-	-	-	-	42.2	2.77	42.2	3.56	1.45
	40	1 1/2"	75	13.5	153	25	26.0	26.0	-	-	38.10	1.65	48.3	2.77	48.3	3.68	1.32
50	50	2"	90	13.5	173	30	32.0	32.0	-	-	50.80	1.65	60.3	2.77	60.3	3.91	2.25
80	65	2 1/2"	-	-	216	30	-	62.0	-	-	63.50	1.65	73.0	3.05	73.0	5.16	8.60
	80	3"	-	-	254	30	-	62.0	-	-	76.20	1.65	88.9	3.05	88.9	5.49	8.00
100	100	4"	-	-	305	30	-	76.0	-	-	101.60	2.11	114.3	3.05	114.3	6.02	24.10

* only for investment cast design ** only for forged design MG = diaphragm size For materials see overview on page 13

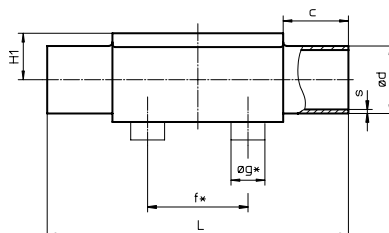

Body dimensions [mm]

Threaded connections, connection code 6, 62
Valve body material: investment casting (code 34), forged body (code 40)

MG	DN	H1*	H1**	f*	øg*	ød1	Thread to DIN 405 R	Code 6 L	Code 62 L	Weight [kg]
8	10	8.5	-	-	-	10.0	RD 28 x 1/8	92	90	0.21
10	10	12.5	-	30.0	13.5	10.0	RD 28 x 1/8	118	116	0.33
	15	12.5	-	30.0	13.5	16.0	RD 34 x 1/8	118	116	0.35
25	15	13.0	19	40.0	13.5	16.0	RD 34 x 1/8	118	116	0.71
	20	16.0	19	40.0	13.5	20.0	RD 44 x 1/6	118	114	0.78
40	25	19.0	19	40.0	13.5	26.0	RD 52 x 1/6	128	127	0.79
	32	24.0	26	68.0	13.5	32.0	RD 58 x 1/6	147	147	1.66
50	40	26.0	26	75.0	13.5	38.0	RD 65 x 1/6	160	160	1.62
	50	32.0	32	90.0	13.5	50.0	RD 78 x 1/6	191	191	2.70
80	65	-	62	-	-	66.0	RD 95 x 1/6	246	246	9.22
	80	-	62	-	-	81.0	RD 110 x 1/4	256	256	9.20

* only for investment cast design

** only for forged design

MG = diaphragm size

For materials see overview on page 13

Code 6

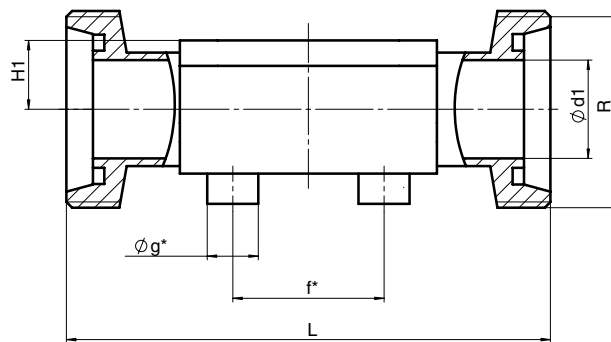

Code 62

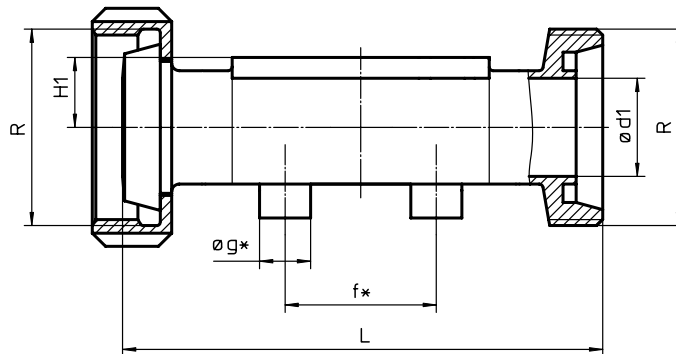

Body dimensions [mm]

Flanges - DIN EN 1092, connection code 8 Valve body material: 1.4435 (code 34, 40), 1.4408 (code 39)

MG	DN	øD	øk	øL	Number of bolts	H1			FTF	Weight [kg]
						Material code 34	Material code 39	Material code 40		
25	15	95	65	14	4	13.0	18.0	19.0	130*	1.85
	20	105	75	14	4	16.0	20.5	19.0	150	2.35
	25	115	85	14	4	19.0	23.0	19.0	160	2.85
40	32	140	100	18	4	24.0	28.7	26.0	180	4.90
	40	150	110	18	4	26.0	33.0	26.0	200	5.65
50	50	165	125	18	4	32.0	39.0	32.0	230	7.45
80	65	185	145	18	4	-	51.0	62.0	290	10.20
	80	200	160	18	8	-	59.5	62.0	310	14.20
100	100	220	180	18	8	-	73.0	76.0	350	21.00

*Material code 34, 40 FTF = 150 (no DIN length)

MG = diaphragm size

For materials see overview on page 13

Flanges - ANSI class 150 RF, connection code 38, 39 Valve body material: 1.4435 (code 34, 40), 1.4408 (code 39)

MG	DN	øD	øk	øL	Number of bolts	H1			FTF		Weight [kg]
						Material code 34	Material code 39	Material code 40	Connection code 38	Connection code 39	
25	15	90	60.3	15.9	4	13.0	18.0	19.0	-	130	1.85
	20	100	69.9	15.9	4	16.0	20.5	19.0	146	150	2.35
	25	110	79.4	15.9	4	19.0	23.0	19.0	146	160	2.85
40	32	115	88.9	15.9	4	24.0	28.7	26.0	-	180	4.90
	40	125	98.4	15.9	4	26.0	33.0	26.0	175	200	5.65
50	50	150	120.7	19.0	4	32.0	39.0	32.0	200	230	7.45
80	65	180	139.7	19.0	4	-	51.0	62.0	226	290	10.20
	80	190	152.4	19.0	4	-	59.5	62.0	260	310	14.20
100	100	230	190.5	19.0	8	-	73.0	76.0	327	350	21.00

MG = diaphragm size

For materials see overview on page 13

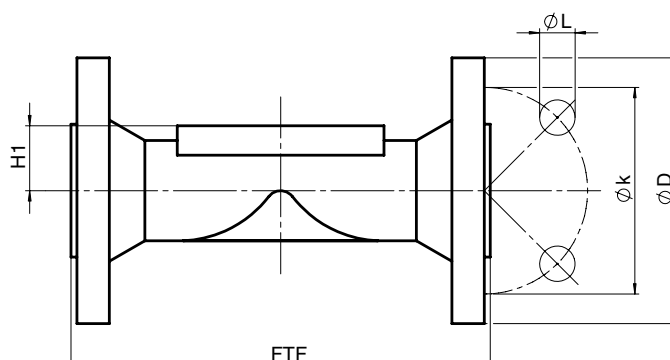

Body dimensions [mm]

Clamp connections, connection code 80, 82, 88, 8A, 8E Valve body material: forged body (code 40)

				for pipe ASME BPE Code 80			for pipe EN ISO 1127 Code 82			for pipe ASME BPE Code 88			for pipe DIN 11850 Code 8A			for pipe SMS 3008 Code 8E			Weight [kg]
MG	DN	NPS	H1	ød1	ød3	L	ød1	ød3	L	ød1	ød3	L	ød1	ød3	L	ød1	ød3	L	
8	6	1/8"	8.5	-	-	-	7.0	25.0	63.5	-	-	-	6	25.0	63.5	-	-	-	-
	8	1/4"	8.5	4.57	25.0	63.5	10.3	25.0	63.5	-	-	-	8	25.0	63.5	-	-	-	0.15
	10	3/8"	8.5	7.75	25.0	63.5	-	-	-	-	-	-	10	34.0	88.9	-	-	-	0.18
	15	1/2"	8.5	9.40	25.0	63.5	-	-	-	9.40	25.0	108	-	-	-	-	-	-	0.18
10	10	3/8"	12.5	-	-	-	14.0	25.0	108.0	-	-	-	10	34.0	108.0	-	-	-	0.30
	15	1/2"	12.5	9.40	25.0	88.9	18.1	50.5	108.0	9.40	25.0	108	16	34.0	108.0	-	-	-	0.43
	20	3/4"	12.5	15.75	25.0	101.6	-	-	-	15.75	25.0	117	-	-	-	-	-	-	0.43
25	15	1/2"	19.0	-	-	-	18.1	50.5	108.0	-	-	-	16	34.0	108.0	-	-	-	0.75
	20	3/4"	19.0	15.75	25.0	101.6	23.7	50.5	117.0	15.75	25.0	117	20	34.0	117.0	-	-	-	0.71
	25	1"	19.0	22.10	50.5	114.3	29.7	50.5	127.0	22.10	50.5	127	26	50.5	127.0	22.6	50.5	127	0.63
40	32	1 1/4"	26.0	-	-	-	38.4	64.0	146.0	-	-	-	32	50.5	146.0	31.3	50.5	146	1.62
	40	1 1/2"	26.0	34.80	50.5	139.7	44.3	64.0	159.0	34.80	50.5	159	38	50.5	159.0	35.6	50.5	159	1.50
50	50	2"	32.0	47.50	64.0	158.8	56.3	77.5	190.0	47.50	64.0	190	50	64.0	190.0	48.6	64.0	190	2.50
80	65	2 1/2"	62.0	60.20	77.5	193.8	72.1	91.0	216.0	60.20	77.5	216	66	91.0	216.0	60.3	77.5	216	8.90
	80	3"	62.0	72.90	91.0	222.3	84.3	106.0	254.0	72.90	91.0	254	81	106.0	254.0	72.9	91.0	254	8.50
100	100	4"	76.0	97.38	119.0	292.1	109.7	130.0	305.0	97.38	119.0	305	100	119.0	305.0	97.6	119.0	305	24.80

MG = diaphragm size

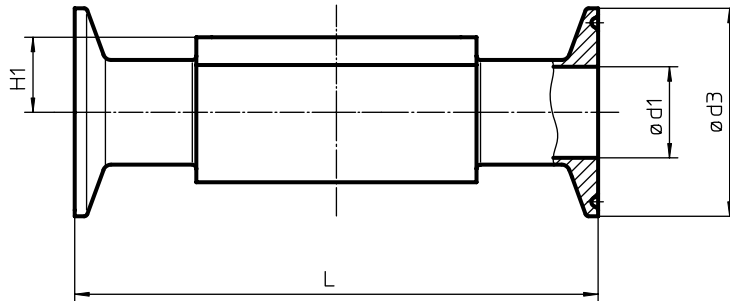

Overview of valve bodies for GEMÜ 653/654

		Threaded connections						Spigots																											
Connection code		1		6		62		0		16		17		18		1A		1B		35		36		37		55		59		60		63		65	
Material code		34	37	34	40	34	40	34	40	34	40	34	40	34	40	40	40	34	40	40	34	40	40	34	40	34	40	34	40	40	40				
MG	DN																																		
8	4	-	-	-	-	-	X	X	-	-	-	-	-	-	-	-	-	-	-	-	-	-	-	-	-	-	-	-	-	-	-	-	-	-	
	6	-	-	-	-	-	X	X	-	-	-	-	-	-	-	X	X	-	-	X	-	-	-	-	-	-	-	-	-	-	X	X	X		
	8	X	-	-	-	-	X	X	-	-	-	-	-	-	-	X	X	-	-	X	-	-	X	X	X	X	X	X	X	X	X	X	X		
	10	-	-	W	W	W	W	-	-	X	X	X	X	X	X	X	X	-	-	X	-	-	X	X	X	X	-	-	-	-	-	-	-		
	15	-	-	-	-	-	-	-	-	-	-	-	-	-	-	-	-	-	-	-	-	-	-	X	X	X	X	-	-	-	-	-	-		
10	10	-	-	W	W	W	W	-	-	X	X	X	X	X	X	X	X	-	-	X	-	-	X	-	X	X	X	X	X	X	X	X	X		
	12	X	-	-	-	-	-	-	-	-	-	-	-	-	-	-	-	-	-	-	-	-	-	-	-	-	-	-	-	-	-	-			
	15	X	-	W	W	W	W	X	X	X	X	X	X	X	X	X	X	-	-	X	-	-	X	X	-	X	X	X	X	X	X	X	X		
	20	-	-	-	-	-	-	-	-	-	-	-	-	-	-	-	-	-	-	-	-	-	X	X	X	X	-	-	-	-	-	-	-		
25	15	-	X	W	W	W	W	X	X	X	X	X	X	-	X	X	X	-	-	X	-	-	-	-	-	-	-	-	X	X	X	X	X		
	20	-	X	W	W	W	W	X	X	X	X	X	X	-	X	X	X	-	-	X	-	-	X	X	X	X	X	X	X	X	X	X	X		
	25	-	X	W	W	W	W	X	X	X	X	X	X	X	X	X	X	X	X	X	X	X	X	X	-	-	X	X	X	X	X	X	X		
40	32	-	X	W	W	W	W	X	X	X	X	X	X	X	X	X	X	X	X	X	X	X	X	X	-	-	-	-	X	X	X	X	X		
	40	-	X	W	W	W	W	X	X	X	X	X	X	X	X	X	X	X	X	X	X	X	X	X	-	-	X	X	X	X	X	X	X		
50	50	-	X	W	W	W	W	X	X	X	X	X	X	X	X	X	X	X	X	X	X	X	X	X	-	-	X	X	X	X	X	X	X		
80	65	-	-	-	W	-	W	-	-	-	-	-	X	-	-	X	X	-	X	X	-	X	-	-	-	-	X	-	X	X	X	X			
	80	-	-	-	W	-	W	-	-	-	-	-	X	-	-	X	X	-	X	X	-	X	-	-	-	-	X	-	X	X	X	X			
100	100	-	-	-	-	-	-	-	-	-	-	-	X*	-	-	X*	X*	-	X*	X*	-	X*	X*	-	X*	-	X*	-	X*	-	X*	X*	X*		

*Valve bodies are not suitable for use with diaphragm code 5E
 X = Standard W = Welded construction

MG = diaphragm size

Overview of valve bodies for GEMÜ 653/654

		Clamps					Flanges						
Connection code		80	82	88	8A	8E	8			38	39		
Material code		40	40	40	40	40	34	39	40	39	34	39	40
MG	DN												
8	6	-	K	-	K	-	-	-	-	-	-	-	-
	8	K	K	-	K	-	-	-	-	-	-	-	-
	10	K	-	-	W	-	-	-	-	-	-	-	-
	15	K	-	W	-	-	-	-	-	-	-	-	-
10	10	-	K	-	K	-	-	-	-	-	-	-	-
	15	K	W	K	K	-	-	-	-	-	-	-	-
	20	K	-	K	-	-	-	-	-	-	-	-	-
25	15	-	W	-	K	-	W	X	W	-	W	X	W
	20	K	K	K	K	-	W	X	W	X	W	X	W
	25	K	K	K	K	K	W	X	W	X	W	X	W
40	32	-	W	-	K	K	W	X	W	-	W	X	W
	40	K	W	K	K	K	W	X	W	X	W	X	W
50	50	K	W	K	K	K	W	X	W	X	W	X	W
80	65	K	K	K	K	K	-	-	W	-	-	-	W
	80	K	W	K	W	W	-	X	W	X	-	X	W
100	100	W*	W*	W*	W*	W*	-	X	W*	X	-	X	W*

*Valve bodies are not suitable for use with diaphragm code 5E
 X = Standard K = Connections completely machined (not welded) in material code 40
 W = Welded construction

MG = diaphragm size

Availability of material code 32: same as code 34, availability of material code 42: same as code 40

Special versions

Additional function A
with seal adjuster, stroke limiter
and mounting for proximity switches M 8x1

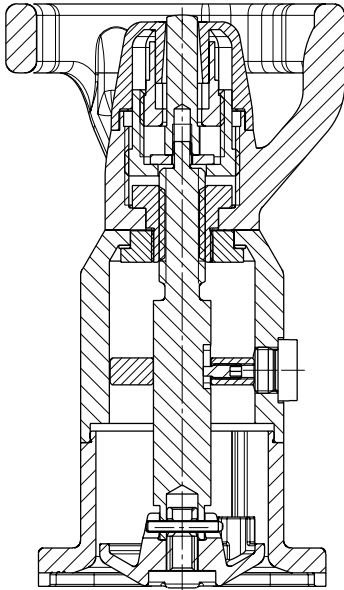

Additional function E
with seal adjuster, stroke limiter
and safety gland packing

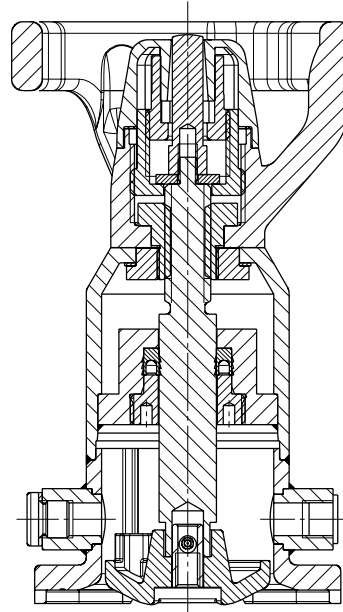

Additional function B, K, F

Types of locking devices

<p>B</p>	<p>B Mounting of locking device (both directions), proximity switch possible</p>
<p>K</p>	<p>K Mounting of locking device to prevent opening, proximity switch possible</p>
<p>F</p>	<p>F Mounting of locking device to prevent closing, proximity switch possible</p>

Type of accessory

MAG - Electrical locking device

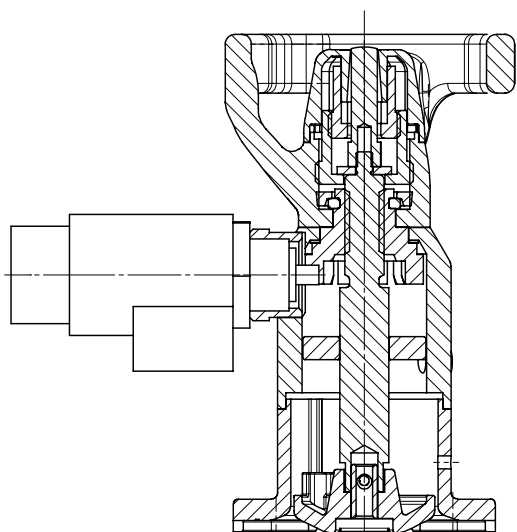

LOC - Mechanical locking device

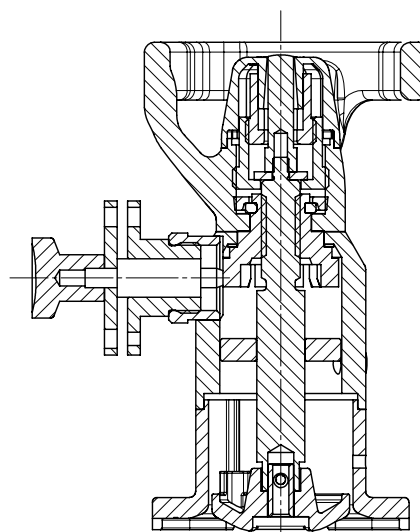

The solenoids, padlocks etc. for the "locking device" must be ordered separately as accessories.
Available only in connection with the bonnet additional functions B, K, F!

Order example	653	MAG	SV	1	C1
Type	653				
Type of accessory		MAG			
Kit			SV		
Control function (code)				1	
Voltage/Frequency (code)					C1

Type of accessory	MAG	- Electrical locking device
Control function	1	- Normally closed (locking device active)
Control function	2	- Normally open (locking device inactive)
Voltage/Frequency	C1	- 24 V DC

Type of accessory	LOC	- Mechanical locking device
Control function	B	- without padlock
	L	- with padlock

EDP No.	Designation	Description
88264576	653MAGSV1 C1 AT	Electromagnetic locking device 24 V DC, normally closed, M22x1 ATEX
88232776	653MAGSV1 C1	Electromagnetic locking device 24 V DC, normally closed, M22x1 IP 54, connector socket design A DIN EN 175301-803
88279388	653MAGSV2 C1	Electromagnetic locking device 24 V DC, normally open, M22x1 IP 54, connector socket design A DIN EN 175301-803
88239348	653LOCSVL	Locking device M22x1 with padlock
88239405	653LOCSVB	Locking device M22x1 without padlock

GEMÜ 654 - 0TN (MG 8)



GEMÜ 654 - 0TH (MG 8)



GEMÜ 653 - T (MG 10 - 100)



GEMÜ 654 - T (MG 10 - 100)



GEMÜ 653 - D (MG 10 - 50)



GEMÜ 654 - D (MG 10 - 50)



GEMÜ 653 - LOC



GEMÜ 654 - MAG



GEMÜ 653 - proximity switches



For further metal diaphragm valves, accessories and other products, please see our Product Range catalogue and Price List. Contact GEMÜ.

GEMÜ® VALVES, MEASUREMENT AND CONTROL SYSTEMS

